

Precision joints with plain and needle bearing series G and H according to DIN 808

Series G is provided with plain bearings, series H with needle bearings. Series H requires neither lubrication nor maintenance, since its bearings are permanently lubricated.

For low-speed applications (max. 1,000 rpm) precision joints with plain bearings (series G) are recommended. They are able to absorb shock loads, irregular rotation and relatively high torques. With high speeds, relatively low torques, reversing operation or big diffraction angles precision joints with needle bearings (series H) should be preferred. Considering the diffraction angle they can be used up to a speed of 4,000 rpm.

The maximum diffraction angle is 45° for single joints and 90° for double joints.

Joints made of stainless steel series X according to DIN 808

Joints series X are fully made of stainless steel 1.4301. The maximum diffraction angle is 45° for single joints and 90° for double joints. The maximum permissible speed for series X is 300 rpm.

Selection criteria

The permissible torque transmission of a joint over a more or less long period considering constant and shock-free load mainly depends on the number of revolutions per minute and the diffraction angle.

The diagrammes on pages 356 - 357 were created based on such criteria.

The figures in the diagramme shall be considered as reference values referring to single joints only. With the selection of a double joint it must be considered that it is able to transmit a torque falling below that of a single joint of the same size by about 10 %. Every application has special properties, e. g. shock loads, change of direction of rotation, mass moment of inertia, start/stop operation, start-up characteristics etc. that have to be considered with the selection of the joint.

Instructions for correct assembly

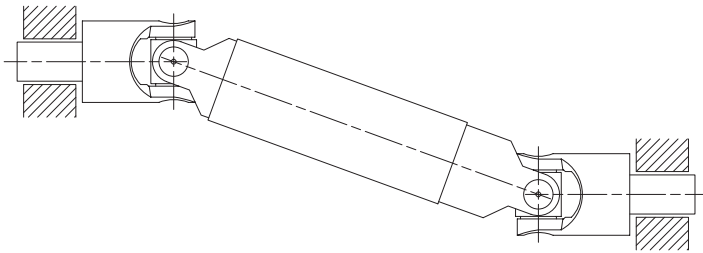

Illustration 1

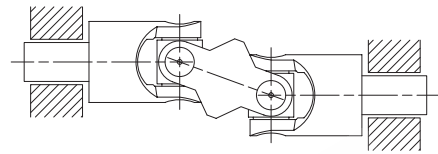

Illustration 2

In order to obtain consistent rotation between driving and driven shaft two single joints or one double joint have to be used. The bearing of the two shafts to be combined should be positioned as close as possible to the joints (see illustration 1 and 2).

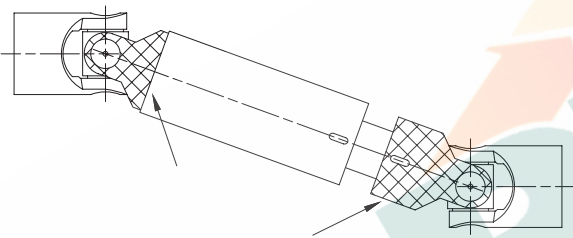

Illustration 3 (correct)

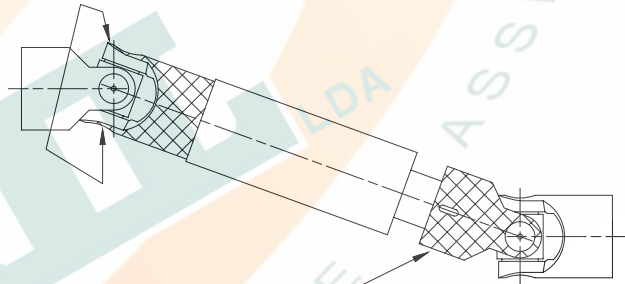

Illustration 4 (not correct)

When using two opposing single joints the identical fork position has to be observed. When using extendable joints it must be made sure that the markings applied are flush (see illustration 3 and 4).

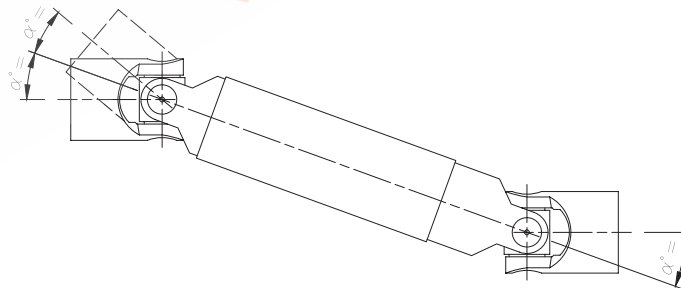
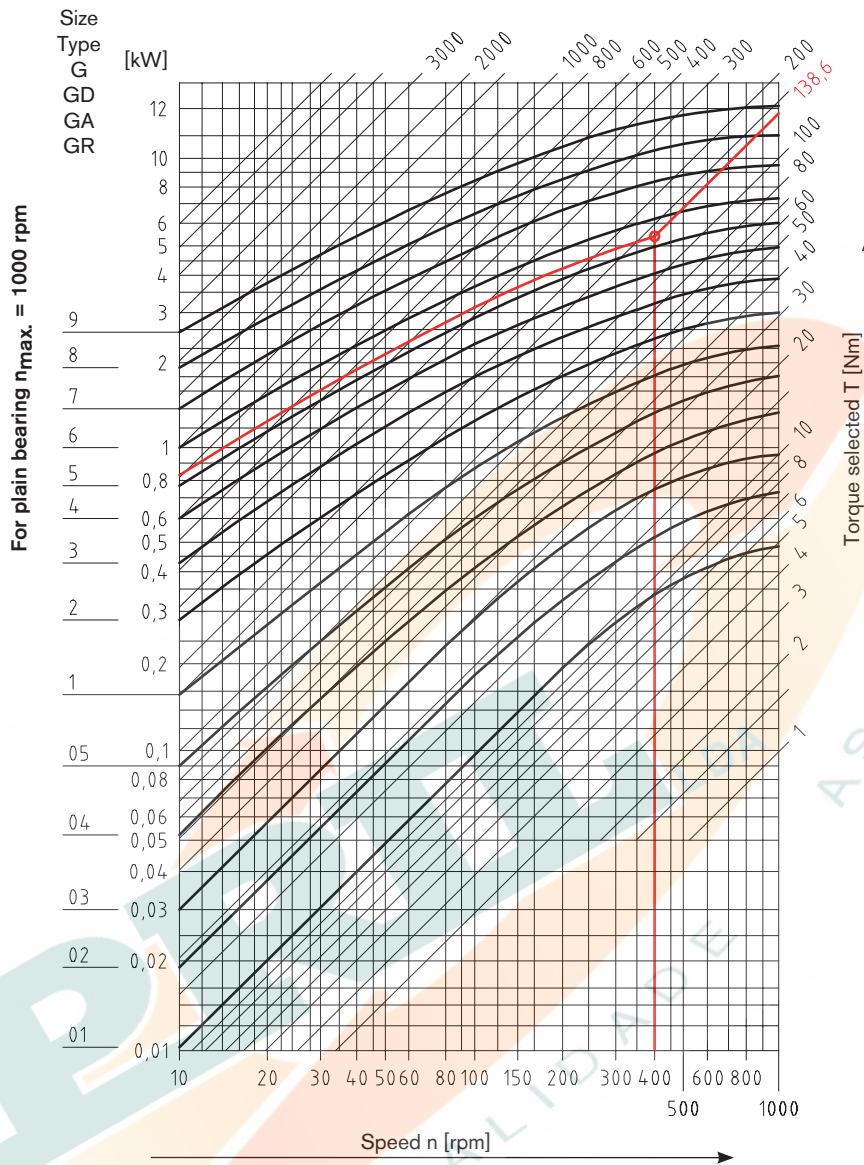

Illustration 5 (correct)

The diffraction angles α° must be identical (see illustration 5). The shafts may only be arranged in parallel or symmetrically to one another.

Selection and sizing according to DIN 808 with plain/needle bearing



Selection of type G, GD, GA, GR (max. 1000 rpm) ¹⁾

The selection of precision joints with plain bearing is based on the driving torque considering a correction factor which depends on the diffraction angle α and the operating speed.

For extendable joints the overall length and the speed need to be additionally considered for sizing (please consult with KTR).

$$\text{Driving torque } M_t \text{ [Nm]} = 9550 \cdot \frac{\text{Power [kW]}}{\text{Speed [rpm]}}$$

$$\text{Torque selected } T \text{ [Nm]} = \text{driving torque} \cdot \text{correction factor}$$

Additional review:

$$\text{Diffraction angle } [\alpha] \cdot \text{speed [rpm]} \leq 40,000$$

Diffraction angle $[\alpha]$	5°	10°	15°	20°	25°	30°	35°	40°	45°
Correction factor	0.8	1.00	1.25	1.5	1.8	2.2	2.6	3.3	4.0

Details given:

Driving torque M_t 63 Nm
 Diffraction angle 30° → Correction factor for diffraction angle 2.2
 Operating speed 400 rpm

$$\text{Torque selected } T \text{ [Nm]} = 63 \text{ Nm} \cdot 2.2 \rightarrow 138.6 \text{ Nm}$$

Selection based on table: [joint size 6](#)

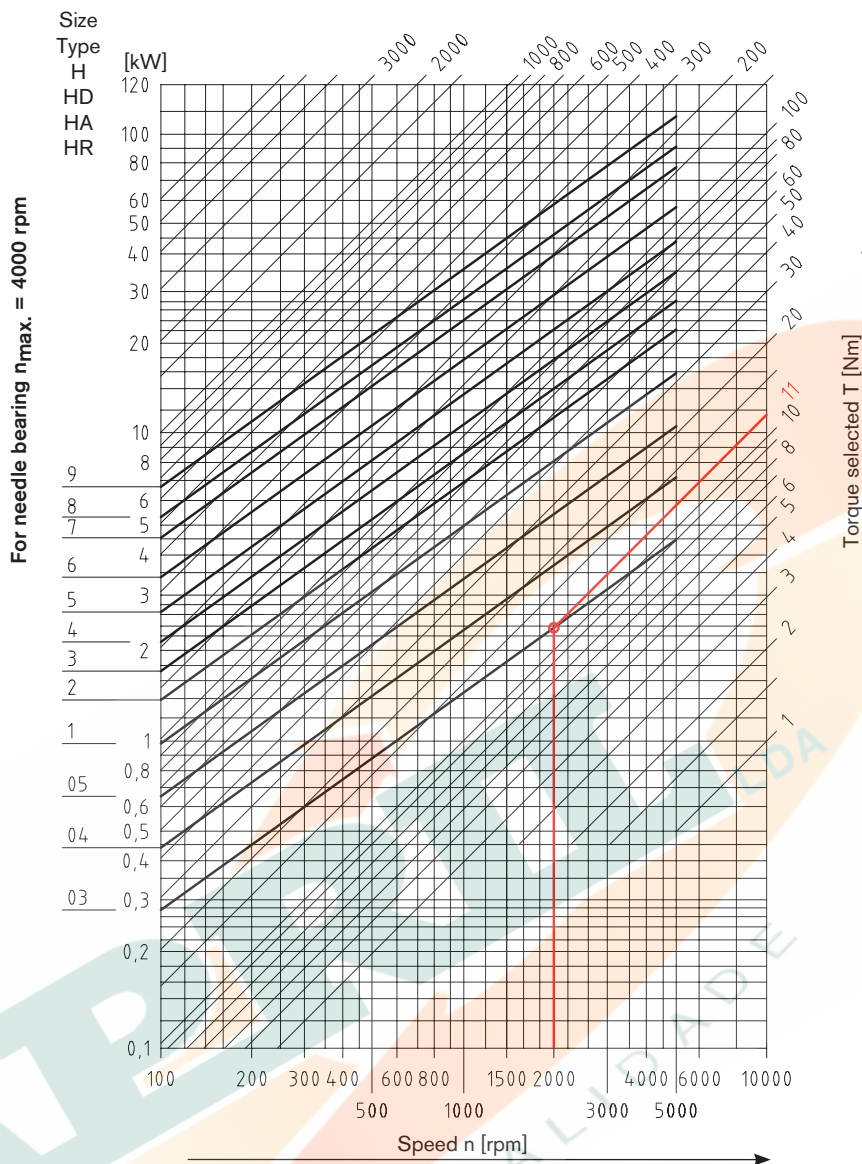

CLAMPEX®

Clamping nuts

Selection of type H, HD, HA, HR (max. 4000 rpm) ¹⁾

The selection of precision joints with needle bearing is based on the driving torque considering a correction factor which depends on the diffraction angle α and the operating speed.

For extendable joints the overall length and the speed need to be additionally considered for sizing (please consult with KTR).

$$\text{Driving torque } M_t \text{ [Nm]} = 9550 \cdot \frac{\text{Power [kW]}}{\text{Speed [rpm]}}$$

$$\text{Torque selected } T \text{ [Nm]} = \text{driving torque} \cdot \text{correction factor}$$

Additional review:

$$\text{Diffraction angle } [\alpha] \cdot \text{speed [rpm]} \leq 40,000$$

Diffraction angle $[\alpha]$	5°	10°	15°	20°	25°	30°	35°	40°	45°
Correction factor	0.8	1.00	1.1	1.25	1.4	2.0	2.5	3.3	4.0

Details given:

Driving torque M_t

8.8 Nm

Diffraction angle

20°

→ Correction factor for diffraction angle 1.25

Operating speed

2000 rpm

$$\text{Torque selected } T \text{ [Nm]} = 8.8 \text{ Nm} \cdot 1.25 \rightarrow 11 \text{ Nm}$$

Selection based on table: [joint size 03](#)

KTR Precision joints

Clamping sets

KTR Precision joints type G and GD

According to DIN 808 with plain bearing



For legend of pictogram refer to flapper on the cover



Precision single joint G

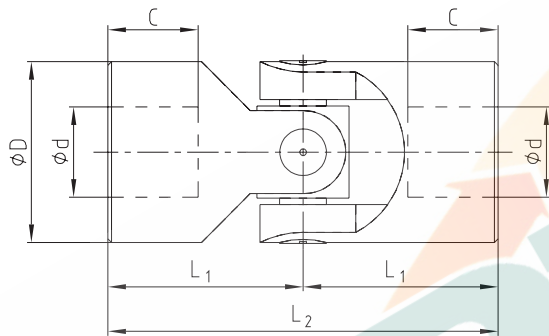

Precision double joint GD

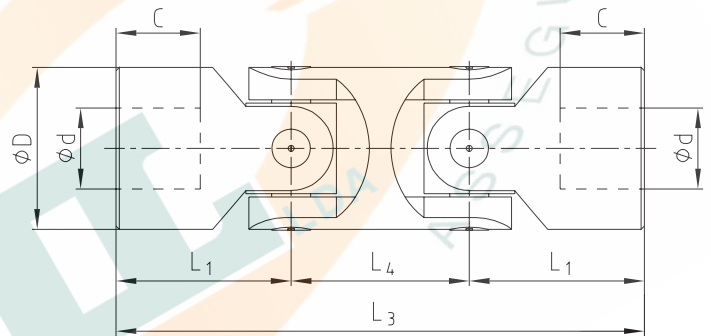

Bore options:

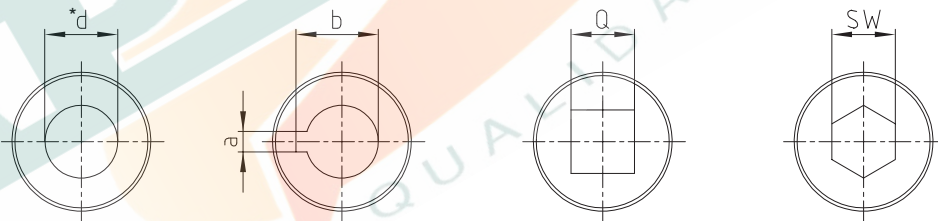

* Standard type of bore, unless differently inquired/ordered

Type G and GD																
Types and size															Weight [kg]	
Size G	DIN designation G	Size GD	DIN designation GD	d (H7)	D	L ₂	L ₁	C	L ₄	L ₃	a (JS9)	b	Q (H10)	SW (H10)	G	GD
01 G	E6 x 16-G	01 GD	D6 x 16-G	6	16	34	17	8	22	56	2	7.0	6	6	0.05	0.08
02 G	E8 x 16-G	02 GD	D8 x 16-G	8	16	40	20	11	22	62	2	9.0	8	8	0.05	0.08
03 G	E10 x 22-G	03 GD	D10 x 22-G	10	22	48	24	12	26	74	3	11.4	10	10	0.10	0.15
04 G	E12 x 25-G	04 GD	D12 x 25-G	12	25	56	28	13	30	86	4	13.8	12	12	0.16	0.25
05 G	E14 x 28-G	05 GD	D14 x 28-G	14	28	60	30	14	36	96	5	16.3	14	14	0.20	0.40
1 G	E16 x 32-G	1 GD	D16 x 32-G	16	32	68	34	16	37	105	5	18.3	16	16	0.30	0.45
2 G	E18 x 36-G	2 GD	D18 x 36-G	18	36	74	37	17	40	114	6	20.8	18	18	0.45	0.70
3 G	E20 x 42-G	3 GD	D20 x 42-G	20	42	82	41	18	47	129	6	22.8	20	20	0.60	1.00
4 G	E22 x 45-G	4 GD	D22 x 45-G	22	45	95	47.5	22	50	145	6	24.8	22	22	0.95	1.55
5 G	E25 x 50-G	5 GD	D25 x 50-G	25	50	108	54	26	55	163	8	28.3	25	25	1.20	2.00
6 G	E30 x 58-G	6 GD	D30 x 58-G	30	58	122	61	29	68	190	8	33.3	30	30	1.85	2.90
6 G1	E32 x 58-G	6 GD1	D32 x 58-G	32	58	130	65	33	68	198	10	35.3	30	30	2.00	3.00
7 G	E35 x 70-G	7 GD	D35 x 70-G	35	70	140	70	33	72	212	10	38.3	-	-	3.15	4.75
8 G	E40 x 80-G	8 GD	D40 x 80-G	40	80	160	80	38	85	245	12	43.3	-	-	4.60	7.20
9 G	E50 x 95-G	9 GD	D50 x 95-G	50	95	190	95	46	100	290	14	53.8	-	-	7.60	12.0

Ordering example:	04 G	Ø12	Ø12 keyway to DIN
	Size and type of joint	Finish bore (H7)	Finish bore (H7), feather keyway acc. to DIN 6885 sheet 1 (JS9)

KTR Precision joints type H and HD

According to DIN 808 with needle bearing



For legend of pictogram refer to flapper on the cover



Precision single joint type H

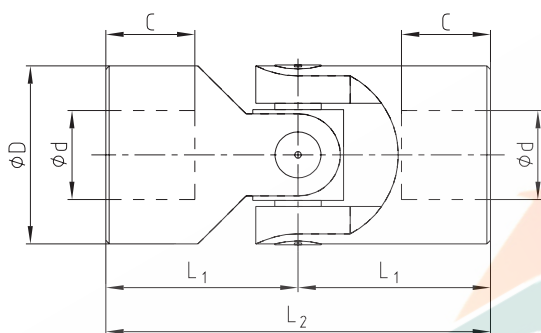

Precision double joint type HD

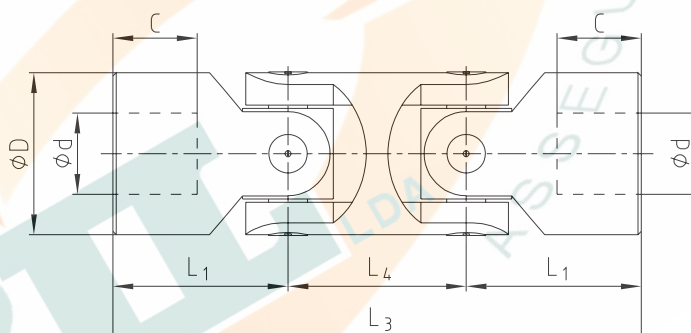

Bore options:

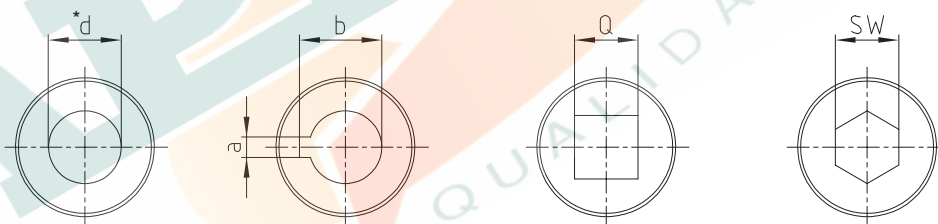

* Standard type of bore, unless differently inquired/ordered

Types and size				Dimensions [mm]										Weight [kg]		
Size H	DIN designation H	Size HD	DIN designation HD	d (H7)	D	L ₂	L ₁	C	L ₄	L ₃	a (JS9)	b	Q (H10)	SW (H10)	H	HD
03 H	E10 x 22-W	03 HD	D10 x 22-W	10	22	48	24	12	26	74	3	11.4	10	10	0.10	0.15
04 H	E12 x 25-W	04 HD	D12 x 25-W	12	25	56	28	13	30	86	4	13.8	12	12	0.16	0.25
05 H	E14 x 28-W	05 HD	D14 x 28-W	14	28	60	30	14	36	96	5	16.3	14	14	0.20	0.40
1 H	E16 x 32-W	1 HD	D16 x 32-W	16	32	68	34	16	37	105	5	18.3	16	16	0.30	0.45
2 H	E18 x 36-W	2 HD	D18 x 36-W	18	36	74	37	17	40	114	6	20.8	18	18	0.45	0.70
3 H	E20 x 42-W	3 HD	D20 x 42-W	20	42	82	41	18	47	129	6	22.8	20	20	0.60	1.00
4 H	E22 x 45-W	4 HD	D22 x 45-W	22	45	95	47.5	22	50	145	6	24.8	22	22	0.95	1.55
5 H	E25 x 50-W	5 HD	D25 x 50-W	25	50	108	54	26	55	163	8	28.3	25	25	1.20	2.00
6 H	E30 x 58-W	6 HD	D30 x 58-W	30	58	122	61	29	68	190	8	33.3	30	30	1.85	2.90
6 H1	E32 x 58-W	6 HD1	D32 x 58-W	32	58	130	65	33	68	198	10	35.3	30	30	2.00	3.00
7 H	E35 x 70-W	7 HD	D35 x 70-W	35	70	140	70	33	72	212	10	38.3	-	-	3.15	4.75
8 H	E40 x 80-W	8 HD	D40 x 80-W	40	80	160	80	38	85	245	12	43.3	-	-	4.60	7.20
9 H	E50 x 95-W	9 HD	D50 x 95-W	50	95	190	95	46	100	290	14	53.8	-	-	7.60	12.0

Ordering example:

1 H	Ø16	Ø16 keyway to DIN
Size and type of joint	Finish bore (H7)	Finish bore (H7), feather keyway acc. to DIN 6885 sheet 1 (JS9)

KTR Precision joints type GA and HA

According to DIN 808 with plain and needle bearing (extendable)

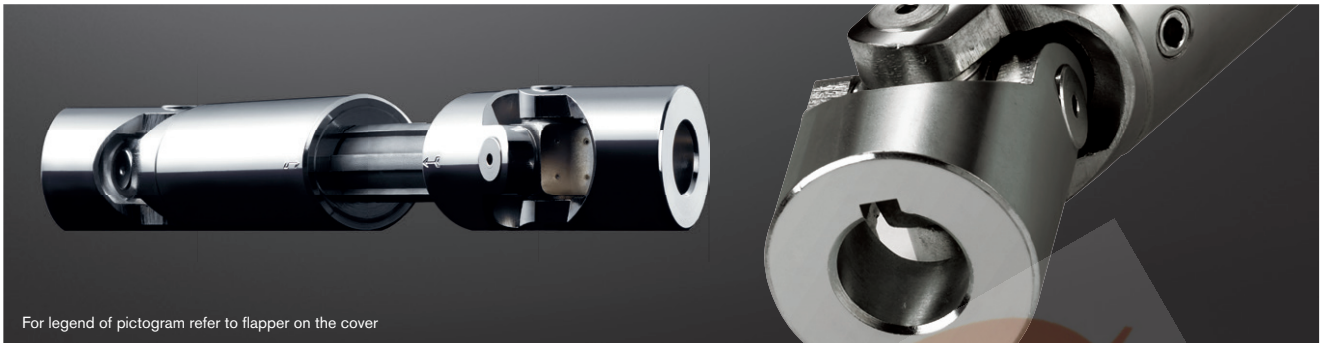

For legend of pictogram refer to flapper on the cover

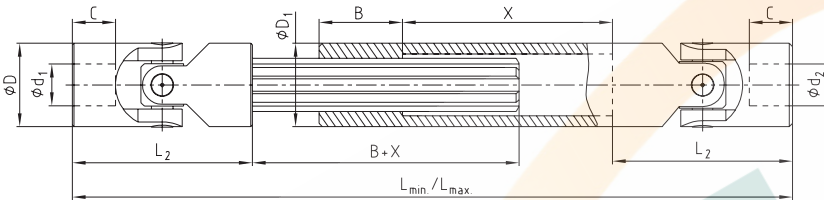
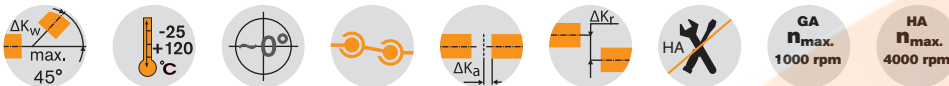

Preferred lengths									
Size	Dimensions [mm]								
	L _{min.} / L _{max.}								
03	140	160	180	230					
	170	200	240	330					
04	160	180	200	220	250	280	300		
	190	225	270	300	355	420	450		
05	170	180	200	220	250	280	300	350	400
	200	220	260	300	350	420	450	550	650
1	190	210	240	250	275	300	380	400	
	220	250	320	350	390	430	590	630	
2	230	250	270	290	300	400	500		
	280	320	370	400	415	620	820		
3	250	270	290	320	380	420	500		
	300	340	380	440	560	640	800		
4	250	270	290	330	350	470			
	280	320	350	430	470	710			
5	295	310	350	380	420	460	500		
	345	375	450	500	590	660	745		
6	330	350	370	400	450	500	540		
	380	420	455	510	620	720	795		

Bore options:

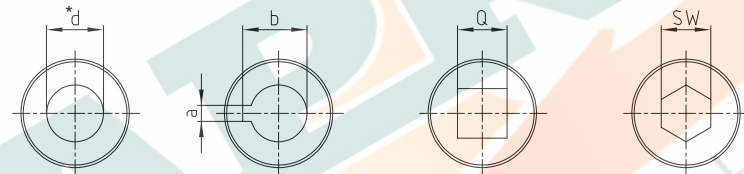

* Standard type of bore, unless differently inquired/ordered

Type GA with plain bearing n _{max.} = 1000 rpm and type HA with needle bearing n _{max.} = 4000 rpm													
Size		Dimensions [mm]										Splines shaft	D ₁
GA	HA	d ₁ , d ₂ (H7)	D	L ₂	C	L _{min.} / L _{max.} / X	B	a (JS9)	b	Q (H10)	SW (H10)		
01 GA	-	6	16	34	8	← →	25	2	7.0	6	6	SW8	16
02 GA	-	8	16	40	11	← →	25	2	9.0	8	8	SW8	16
03 GA	03 HA	10	22	48	12	← →	30	3	11.4	10	10	11 x 14 Z6	22
04 GA	04 HA	12	25	56	13	← →	40	4	13.8	12	12	13 x 16 Z6	26
05 GA	05 HA	14	28	60	14	← →	40	5	16.3	14	14	13 x 16 Z6	29
1 GA	1 HA	16	32	68	16	← →	40	5	18.3	16	16	16 x 20 Z6	32
2 GA	2 HA	18	36	74	17	← →	40	6	20.8	18	18	18 x 22 Z6	37
3 GA	3 HA	20	42	82	18	← →	45	6	22.8	20	20	21 x 25 Z6	42
4 GA	4 HA	22	45	95	22	← →	45	6	24.8	22	22	23 x 28 Z6	47
5 GA	5 HA	25	50	108	26	← →	45	8	28.3	25	25	26 x 32 Z6	52
6 GA	6 HA	30	58	122	29	← →	50	8	33.3	30	30	32 x 38 Z8	58
7 GA	7 HA	35	70	140	33	← →	70	10	38.3	-	-	36 x 42 Z8	70
8 GA	8 HA	40	80	160	38	← →	80	12	43.3	-	-	42 x 48 Z8	80
9 GA	9 HA	50	95	190	46	← →	90	14	53.8	-	-	46 x 54 Z8	95

Calculation of mounting lengths L and X (stroke)

$$\text{Stroke } X \geq \frac{L_{\max.} - 2 \cdot L_2 - B}{2}$$

$$L_{\min.} \geq \frac{L_{\max.} + 2 \cdot L_2 + B}{2}$$

$$\text{Minimum size } L_{\min.} = L_2 + B + X + L_2$$

Ordering example:	3 GA	d ₁ = Ø20	d ₂ = Ø20 keyway to DIN	550/650
	Size and type of joint	Finish bore (H7)	Finish bore (H7), feather keyway acc. to DIN 6885 sheet 1 (JS9)	Mounting length L _{min.} /L _{max.}

KTR Precision joints type X and XD

According to DIN 808 with plain bearing made of stainless steel 1.4301

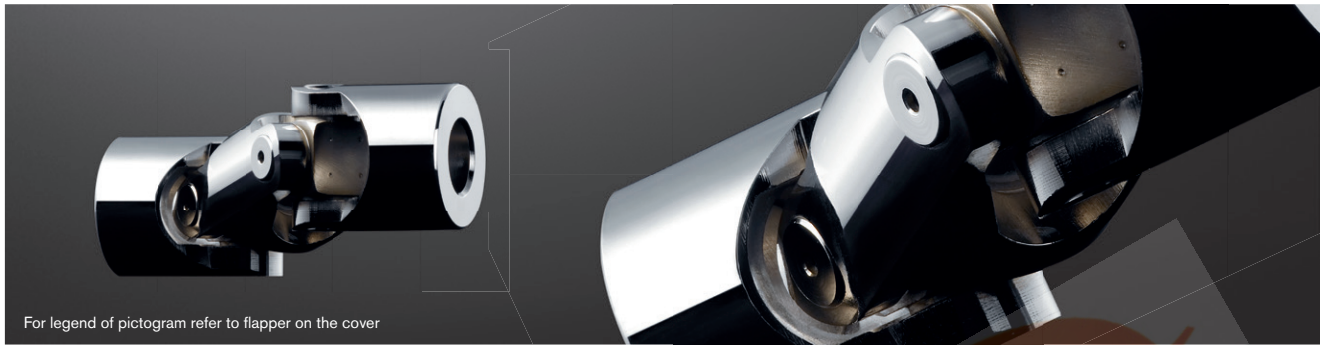

For legend of pictogram refer to flapper on the cover



Precision single joint X

Precision double joint XD

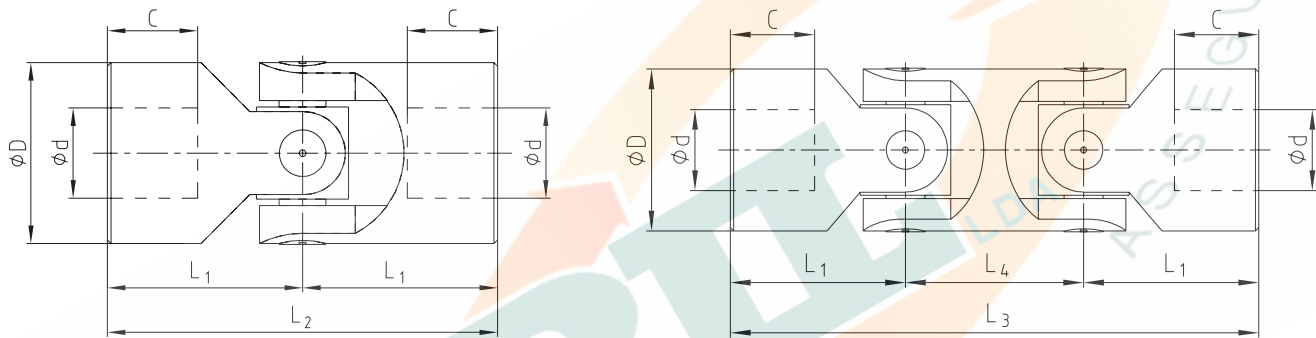

Bore options:

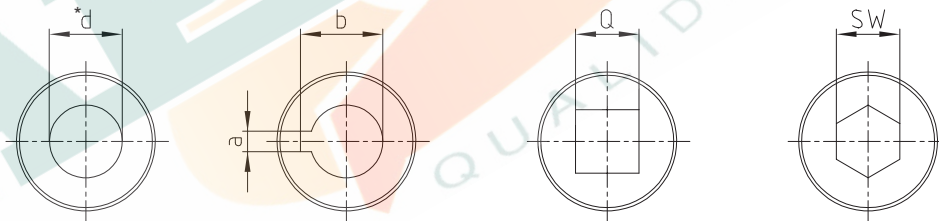

* Standard type of bore, unless differently inquired/ordered

Type X and XD																
Types and size				Dimensions [mm]											Weight [kg]	
Size X	DIN designation X	Size XD	DIN designation XD	d (H7)	D	L ₂	L ₁	C	L ₄	L ₃	a (JS9)	b	Q (H10)	SW (H10)	X	XD
01 X	E6 x 16-G	01 XD	D6 x 16-G	6	16	34	17	8	22	56	2	7.0	6	6	0.05	0.08
02 X	E8 x 16-G	02 XD	D8 x 16-G	8	16	40	20	11	22	62	2	9.0	8	8	0.05	0.08
03 X	E10 x 22-G	03 XD	D10 x 22-G	10	22	48	24	12	26	74	3	11.4	10	10	0.10	0.15
04 X	E12 x 25-G	04 XD	D12 x 25-G	12	25	56	28	13	30	86	4	13.8	12	12	0.16	0.25
05 X	E14 x 28-G	05 XD	D14 x 28-G	14	28	60	30	14	36	96	5	16.3	14	14	0.20	0.40
1 X	E16 x 32-G	1 XD	D16 x 32-G	16	32	68	34	16	37	105	5	18.3	16	16	0.30	0.45
3 X	E20 x 42-G	3 XD	D20 x 42-G	20	42	82	41	18	47	129	6	22.8	20	20	0.60	1.00
5 X	E25 x 50-G	5 XD	D25 x 50-G	25	50	108	54	26	55	163	8	28.3	25	25	1.20	2.00
6 X	E30 x 58-G	6 XD	D30 x 58-G	30	58	122	61	29	68	190	8	33.3	30	30	1.85	2.90

Ordering example:	04 X	Ø12	Ø12 keyway to DIN
	Size and type of joint	Finish bore (H7)	Finish bore (H7), feather keyway acc. to DIN 6885 sheet 1 (JS9)

KTR Precision joints type GR and HR

Plain and needle bearing with quick locking

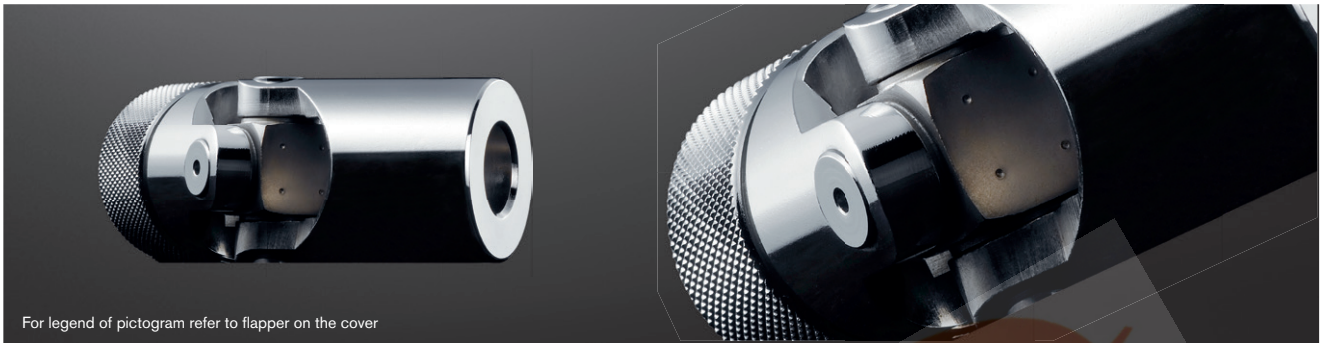

For legend of pictogram refer to flapper on the cover

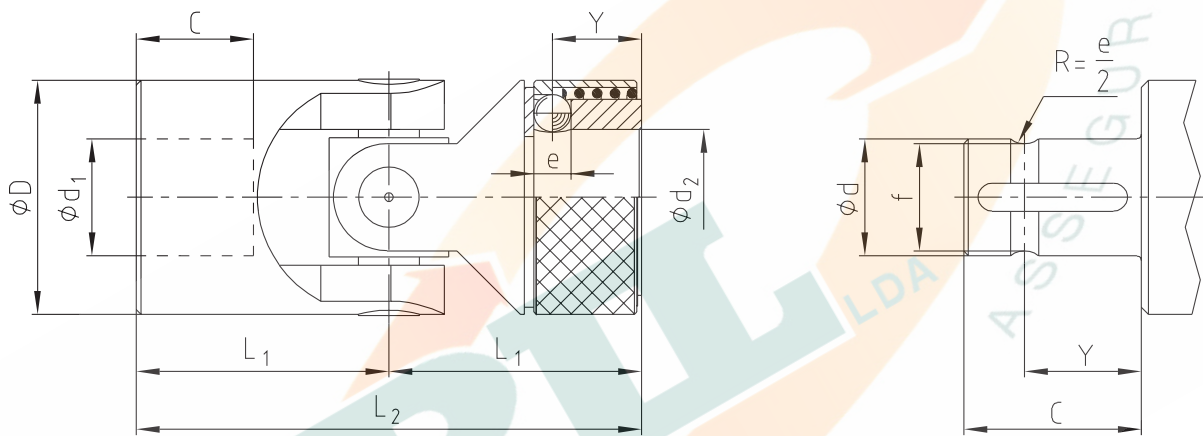

Bore options:

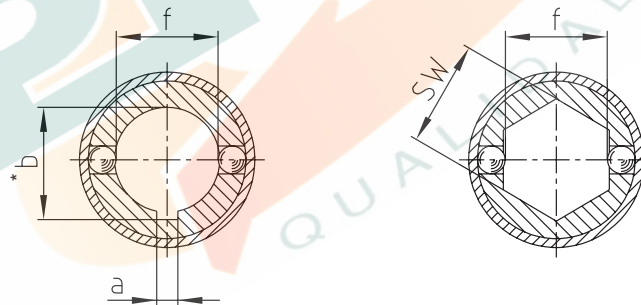

* Standard type of bore, unless differently inquired/ordered

Type GR with plain bearing $n_{max.} = 1000$ rpm and type HR with needle bearing $n_{max.} = 4000$ rpm

Size		Dimensions [mm]											Weight [kg]
GR	HR	d_1, d_2 (H7)	D	L_2	L_1	C	Y	e	f	a (JS9)	b	SW (H10)	
02 GR	-	8	16	52	26	14	9.5	3.5	6.3	2	9.0	8	0.05
03 GR	03 HR	10	22	62	31	17	11.5	4.0	8.7	3	11.0	10	0.12
04 GR	04 HR	12	25	74	37	21	13.5	4.0	11.0	4	13.3	12	0.19
05 GR	05 HR	14	25	74	37	21	13.5	4.0	13.0	5	15.3	14	0.17
1 GR	1 HR	16	32	86	43	24	14.0	6.35	14.8	5	18.3	16	0.34
2 GR	2 HR	18	36	96	48	28	19.0	8.0	16.0	6	20.8	18	0.48
3 GR	3 HR	20	42	108	54	31	19.0	8.0	18.0	6	22.8	20	0.76
4 GR	4 HR	22	45	120	60	34	20.5	10.0	20.0	6	24.8	22	0.97
5 GR	5 HR	25	50	132	66	38	20.5	10.0	23.0	8	28.3	25	1.3
6 GR	6 HR	30	58	166	83	49	25.0	10.0	28.0	8	33.3	30	2.13

Ordering example:

03 HR	$d_1 = \text{Ø}10$	$d_2 = \text{Ø}10$ keyway to DIN
Size and type of joint	Finish bore (H7)	Finish bore (H7), feather keyway acc. to DIN 6885 sheet 1 (JS9)

Protection bushings

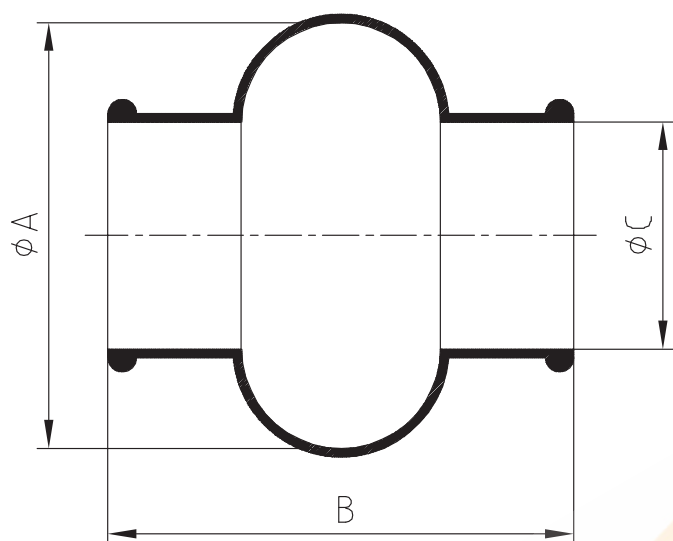

CLAMPEX®

Clamping nuts

Protection bushings				
Size	Precision joints	A	B	C
M 01	01 G, 01 X	28	34	15
M 02	02 G, 02 X, 02 GR	32	40	16.5
M 03	03 G, 03 H, 03 GA, 03 HA, 03 X, 03 GR, 03 HR	40	45	20.5
M 04	04 G, 04 H, 04 GA, 04 HA, 04 X, 04 GR, 04 HR	48	50	24.5
M 05	05 G, 05 H, 05 GA, 05 HA, 05 GR, 05 HR	52	56	27.5
M 1	1 G, 1 H, 1 GA, 1 HA, 1 X, 1 GR, 1 HR	56	65	30.5
M 2	2 G, 2 H, 2 GA, 2 HA, 2 GR, 2 HR	66	72	35.5
M 3	3 G, 3 H, 3 GA, 3 HA, 3 X, 3 GR, 3 HR	75	82	40.0
M 4	4 G, 4 H, 4 GA, 4 HA, 4 GR, 4 HR	84	95	45.0
M 5	5 G, 5 H, 5 GA, 5 HA, 5 X, 5 GR, 5 HR	92	108	50.0
M 6	6 G, 6 G1, 6 H, 6 H1, 6 GA, 6 HA, 6 X, 6GR, 6 HR	100	122	56.0

KTR Precision joints

Clamping sets